

# YDD-L

## LED DUSK TO DAWN YARD LIGHT

49W (5046 lumens)

**UL** **LISTED** **US**  
**Approvals:**  
 cULus listed  
 Suitable for outdoor use.  
**Powered by** **CREE** **LED**

Project: \_\_\_\_\_

Contractor: \_\_\_\_\_



**quick ship**

**5**  
**yr**  
**warranty**



Not all products are qualified on the DLC QPL. To view our DLC qualified products, please consult the DLC Qualified Products List at [www.designlights.org/search](http://www.designlights.org/search).

### DESCRIPTION

The YDD-L is an energy efficient dusk to dawn yard light. It is a versatile and economic light source that is good on the environment and uses long life LED's. The YDD-L comes standard with a photocontrol which helps to provide significant power savings. It includes an installation bracket for pole and wall mounting and a 21" arm for ease and versatility of installation. All units come standard with 6 feet of cable to facilitate the connection to the junction box when mounting with the pole arm.

### TECHNICAL SPECIFICATIONS

- Grey die cast housing
- Standard with photocell (120V only) and 21" arm
- Input voltage: 120V AC
- High quality, long life LEDs
- Estimated lifespan of 50 000 hours
- 4000K colour temperature
- Low starting temperature of -40°C

### Accessory (order SEPARATELY)

<b>PH0009</b>	Shorting cap
---------------	--------------

### DIMENSIONS

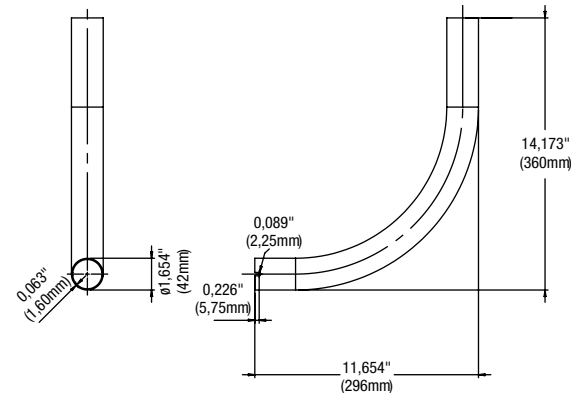
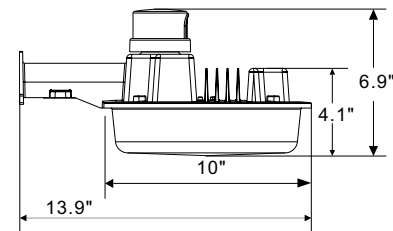

### QUICK SHIP ORDERING GUIDE\*

Part number	Wattage (W)	Lumens	Voltage (V)	Colour temperature	Efficacy (Lm/W)
<b>YDD-LS2-A/4K/PT120</b>	49	5046	120	4000K	103

\* **QUICK SHIP:** Product availability is subject to change without notice. Please contact your Stanpro customer service representative to confirm inventory levels at time of order.